



These two pages indicate the various parts and controls of the LEICA. Compare the illustration on the left with your camera but do not yet operate any knob, button or lever.

- 1** WINDING KNOB  
advances the film and winds shutter in one operation page 4
- 2** AUTOMATIC EXPOSURE COUNTER page 4
- 3** SHUTTER RELEASE page 4
- 4** FILM TYPE INDICATOR page 5
- 5** FAST SHUTTER-SPEED DIAL  
for speeds from 1/15 sec. to 1/1000 sec. and "Bulb" page 6
- 6** SLOW SHUTTER-SPEED DIAL  
for speeds from 1/15 sec. to 1 sec. and "Time" page 7
- 7** IRIS DIAPHRAGM ADJUSTMENT page 11
- 8** FOCUSING LEVER WITH INFINITY CATCH page 12
- 9** DISTANCE SCALE page 12
- 10** DEPTH OF FIELD SCALE page 15

- 11** TWIN EYEPIECE of viewfinder and rangefinder page 16
- 12** VIEWFINDER WINDOW page 17
- 13** RANGEFINDER WINDOWS (two) page 18
- 14** RANGEFINDER EYEPIECE ADJUSTMENT page 19
- 15** REWINDING KNOB pages 27 and 33
- 16** REVERSING LEVER A = Film ADVANCE position  
R = Film REVERSE position page 33
- 17** ACCESSORY SHOE for special viewfinders etc. page 16
- 18** ADJUSTABLE FLASH CONTACT SCALE  
with red contact numbers page 34
- 19** FLASH PLUG SOCKET  
to connect flash attachment cable page 35

You are now ready to practise with the unloaded camera. Continue until you are thoroughly familiar with the instructions given in the following pages and can even operate your LEICA in the dark.



Set reversing lever  
to **A** (= advance).  
It must touch the stop pin.

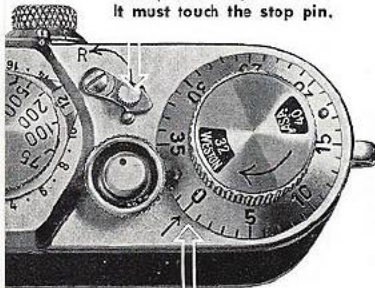

After loading with film 3380a  
set exposure counter to 0



### 1 TURN WINDING KNOB

in the direction indicated by the arrow until it comes to a stop. This operation simultaneously winds the shutter and advances the film for the next exposure. Double exposures are thus prevented.

### 2 THE EXPOSURE COUNTER

automatically registers the number of exposures made, provided it was set to 0 when the new film was inserted. Note: the dial may be turned in an anti-clockwise direction, independently of the knob.

### 3 SHUTTER RELEASE

Press the button gently and firmly, avoiding any jerking movement. Use the index finger of the right hand when the camera is held horizontally, or the right thumb when a vertical picture is being made. A cable release may be screwed over the release button when required.

*Routine Practice:*  
Set exposure counter to 0, wind  
and release shutter repeatedly,  
noting the action of the counter.

*While the shutter is operating the main speed dial revolves. Avoid touching it when pressing the button.*

4

### 4 THE FILM TYPE INDICATOR

on the winding knob is set to the type and speed of film used and a new adjustment made whenever the camera is loaded with different negative material. Film speeds are shown in ASA and Weston Exposure Index Numbers.

To set the film type indicator, lift the milled edge of the winding knob. For black-and-white film turn it in the direction of the engraved arrow and let it drop into place at the correct setting. The lettering will then be in white on black. For colour film lift the milled edge and turn as far as required against the direction of the arrow. The letters ASA and Weston are then in white on red, which shows that the camera is loaded with colour film. The speed figure itself is always white on black.

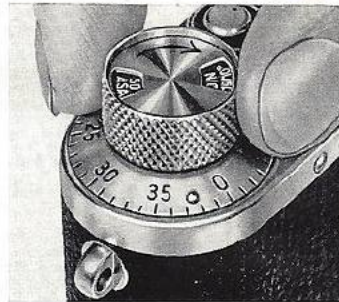

5

## SETTING THE SPEED DIALS



The old fashioned invitation by the portrait photographer to "watch the birdie" has given place to the quiet click of the LEICA shutter.

Modern lenses and emulsions have reduced exposure times from minutes to fractions of a second.

The LEICA Model III f has two shutter speed dials: the main dial on the top and the slow speed dial on the front of the camera.

After winding shutter, lift main speed dial, turn it until the desired speed is opposite the arrow and allow the dial to drop into its catch. At  $\frac{1}{1000}$  sec. the dial will not drop back quite so deeply.

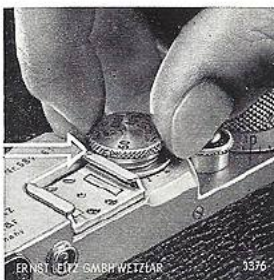

### 5 FAST SHUTTER-SPEED DIAL

The engraved figures are the denominators of the fractions of a second they represent, e. g. 50 indicates  $\frac{1}{50}$  sec., 1000 signifies  $\frac{1}{1000}$  sec. and so on. The speed is set after winding the shutter by raising the dial and turning it until the desired figure falls opposite the arrow. It is then allowed to spring back into its seating. When set to "B" (bulb or brief time) the shutter remains open as long as pressure on the release button is maintained. When the shutter is rewound the dial returns to the position occupied before release. The dial need not, therefore, be adjusted unless a different speed is required.

When exposures longer than  $\frac{1}{25}$  sec. are required the slow shutter-speed dial is brought into play as indicated overleaf.

6

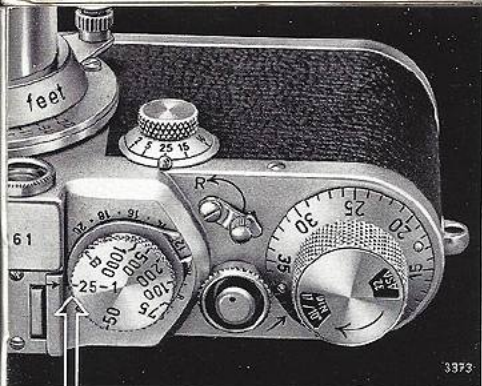

#### IMPORTANT RULE:

For exposures of  $\frac{1}{25}$  sec. and faster the shutter-speed dial on the top of the camera is set to the desired speed, but the slow-speed dial must be first set to red figure 25. To make exposures longer than  $\frac{1}{25}$  sec., first set the top dial to red mark 25-1. Thus, when working at  $\frac{1}{25}$  sec., both dials are set at red figures.

### 6 SLOW SHUTTER-SPEED DIAL

Before setting this dial the top dial of the LEICA III f must be set to the red index 25-1. *This is most important.* The figures on the slow-speed dial can be read from above and provide for exposures of  $\frac{1}{25}$ ,  $\frac{1}{15}$ ,  $\frac{1}{10}$ ,  $\frac{1}{5}$ ,  $\frac{1}{2}$  and 1 sec., and "Time".

This range also covers speeds intermediate between those marked; thus, set half-way between  $\frac{1}{2}$  and 1 sec., the shutter yields an exposure of  $\frac{3}{4}$  sec. Intermediate speeds are not possible in the faster exposure range. When the slow-speed dial is set to "T", the shutter opens on being released and remains open until the slow-speed dial is turned back a little. A safety catch retains the slow-speed dial at the "25" position. This catch is released by the thumb-nail, as shown on the next page, when slower speeds are required.

7

## SETTING SHUTTER SPEEDS – Summary:

### Short Instantaneous Exposures:

from 1/25 to 1/1000 sec.

1. Set slow-speed dial to 25.
2. Wind shutter, lift fast-speed dial and turn to appropriate setting.

### Slow Instantaneous Exposures:

1/25 sec. to 1 sec.

1. Wind shutter and set top speed dial to 25-1.
2. Set slow-speed dial.

### Brief Time (Bulb) Exposures:

1. Set slow-speed dial to 25.
2. Wind shutter and set top dial to B. The shutter will remain open so long as pressure is maintained on the release.

### Time Exposures:

1. Wind shutter and set top speed dial to 25-1.
2. Set slow-speed dial to T.

The shutter opens when pressure is applied to the release button and remains open until the slow-speed dial is turned slightly back.

To release slow-speed dial, press spring catch towards the camera with the thumbnail as shown.



8

## THE STANDARD LENS OF THE LEICA

is the world-famous ELMAR having a maximum aperture of f/3.5 and a focal length of 50 mm. Of the wide range of LEICA lenses it is the most useful general-purpose lens. It is highly corrected to ensure optimum definition. Its aperture is sufficiently wide for all but exceptional purposes.

The SUMMICRON f/2 is of the same focal length but passes three times as much light as the ELMAR at full aperture. As is to be expected it is larger and heavier than the standard lens. It is intended for the experienced LEICA photographer for use under difficult lighting conditions.

Both ELMAR and SUMMICRON are fitted with collapsible mounts, the barrel sliding into the camera body when not in use. The lens is drawn out and locked in position by a slight clockwise turn, and returned to its collapsed position by reversing the movements

- Routine Practice:** 1. Draw out! lock!  
2. Unlock! Push back!

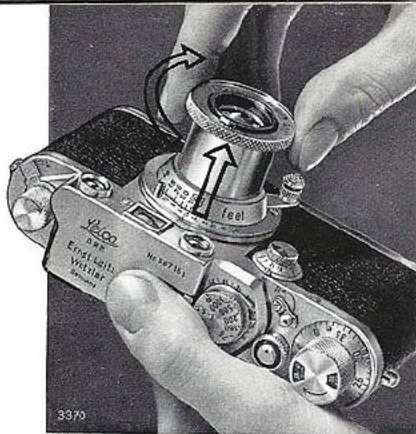

A bluish sheen characterises the "coated" or "bloomed" LEICA lenses. The coating, by reducing surface reflection, minimises loss of light and markedly improves the brilliance and contrast of the picture. The colour in itself is, however, no measure of the effectiveness of the coating.

9

## CHANGING LENSES

All LEICA lenses are interchangeable and will fit any LEICA camera (except very early models). To change a lens hold the camera horizontally, lens pointing upwards, in the left hand, and with the right hand grasp the lens close to the camera body and unscrew it by turning anti-clockwise.

To fit the alternative lens, hold the camera as described and present the lens to the flange in such a way that, in the case of 35 or 50 mm lenses, the focusing



3374

ERNST LEITZ GMBH WETZLAR

lever (8) is directly in front of the viewfinder window (12). Engage the threads by a slight anti-clockwise turn and screw home by turning the lens mount in a clockwise direction. The lens tube should be drawn forward and locked before the lens is fitted to the camera.

When the lens is detached the shutter is visible. It is made of a special rubberised cloth, unaffected by temperature, while its flexibility ensures smooth running. Below the upper rim of the flange opening will be seen the lever which couples the focusing adjustment and the rangefinder. It is actuated by a helix on the lens barrel.

**Rule:** Do not change lenses in direct light. Turn away from the sun and work in the shadow of the body. When carrying extra lenses, fit a dust cover to protect the precision coupling mount. Also put a lens cap over the front component.

10

## 7 IRIS DIAPHRAGM ADJUSTMENT

The human eye is able to adapt itself to varying intensities of light by dilation or contraction of the pupil. The lower the light intensity the wider the pupil becomes and vice versa. The "pupil" of the photographic lens is enlarged or reduced by means of an iris diaphragm. The light-passing value of a lens is governed by the ratio of its focal length to the diameter of the "pupil", and is usually referred to as the "aperture" or "stop".

The numerical value of the stop is stated either as a ratio, thus 1:3.5 or commonly  $f/3.5$ . A lens of this value has a focal length three and a half times as large as the diameter of the pupil. Theoretically, all lenses having the same  $f$ -number pass the same amount of light for the purpose of exposure.

It is customary to graduate the aperture scale on photographic lenses so that the values vary in a 2:1 ratio. Thus, stopping down one division demands a doubling of exposure time, other conditions being equal.

The following table shows the relation between aperture value and exposure time:

Lens aperture:	1.4	1.5	2	2.8	(3.5)	4	5.6	8	11	16	22
Relative exposure time:	0.5	1	2	(3)	4	8	16	32	64	128	



3407a

LEICA lenses ELMAR 50 mm. have the aperture scale engraved on the front of the lens mount. The iris is opened and closed by adjustment of a small lever engraved with an index line. On all other LEICA lenses the diaphragm is controlled by means of a milled ring.



3401

11

## LENS APERTURE and EXPOSURE TIME

Example:

Assuming an exposure time of  $\frac{1}{100}$  sec. is correct for a diaphragm setting of  $f/5.6$ , the exposure time must be doubled, i. e. increased to  $\frac{1}{50}$  sec., if the diaphragm is stopped down to  $f/8$ , other conditions being equal. On the other hand, if the stop were opened up to  $f/4$ , only half of the exposure at  $f/5.6$  would be needed, viz.  $\frac{1}{200}$  sec. Slight differences in the exposure times used, especially somewhat longer times, are of no significance in practice and are covered by the latitude of modern films. For best results in photography, of course, correct exposure times should always be aimed at.

## 8 FOCUSING THE LENS

All LEICA lenses having a focusing lever are automatically locked at the infinity ( $\infty$ ) position. To release the lever for focusing on nearer subjects press the knob at the end of the lever.

**DON'T FORGET:**  
ELMAR 50 mm. and SUMMITAR 50 mm. lenses have collapsible mounts. The lens barrel must be drawn out and locked before focusing. (See page 9.)

## 9 DISTANCE SCALE

Normally, actual distances do not interest LEICA photographers as focusing is effected by the rangefinder. The distance scale, therefore, is of importance only when referring to the depth of field scale described on page 15.



## GENERAL RULES FOR STOPPING DOWN

1. Objects most sharply defined are those at the distance at which the lens is focused. Therefore, always focus carefully on the centre of interest of the subject.
2. Snapshots: Stop down to  $f/5.6$  and focus on principal object. The depth of field will usually be sufficient.
3. Long distance views without foreground interest: Set lens to infinity and stop down to  $f/5.6$  or  $f/8$ .
4. Landscapes with foreground: Stop down so that the depth of field scale indicates a range extending from the foreground distance to infinity.
5. Portraits: Use full lens aperture and focus accurately on the eyes. The sitter should be sharply defined and the background subdued by being diffused.

*The Second Index Line marked R on distance scale is used for infra-red-photography. First focus accurately on the object in the usual way, then adjust the lens mount until index line R registers with the distance indicated by the rangefinder setting. Exceptions: When working with wide-angle lenses, no special adjustment is required.*

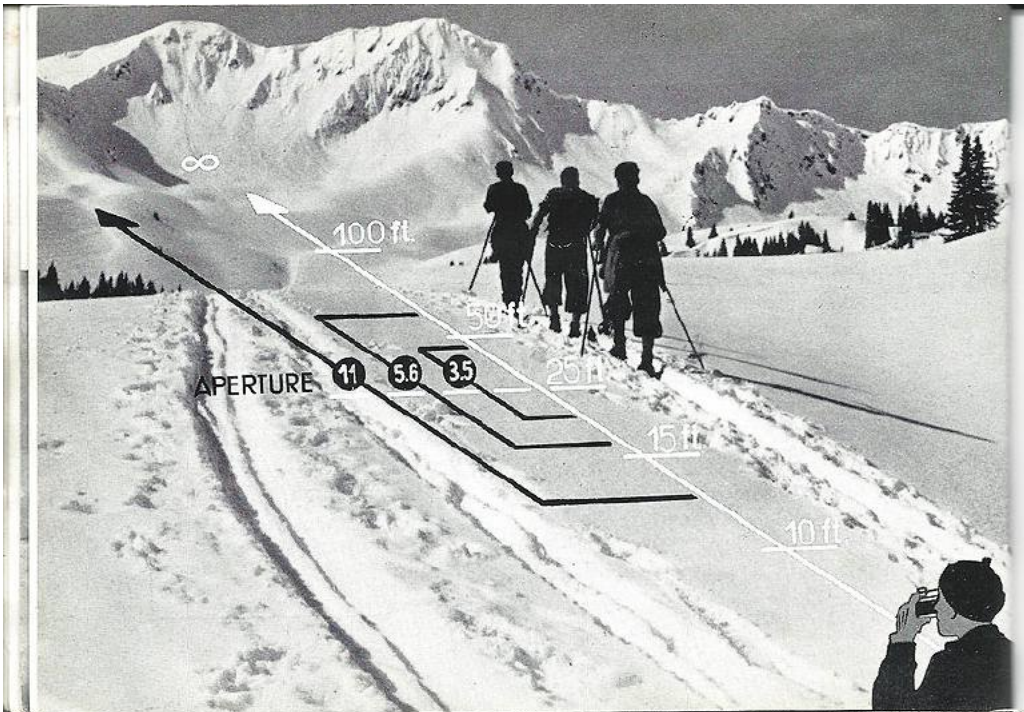

## 10 DEPTH OF FIELD SCALE

An object is most sharply defined in a photograph when it lies at the distance on which the lens is focused. Definition would gradually deteriorate if the object were moved nearer the camera until a point would be reached when definition would be quite unsatisfactory. Similarly, definition would deteriorate, although not so rapidly, if the object were moved away from the camera. The distance between the nearest plane and the furthest plane at which objects are sufficiently sharply defined is known as the "depth of field" (often erroneously called "depth of focus"). It varies with the distance focused upon and the aperture of the lens. The nearer the principal object and the larger the stop of the lens the shallower the depth of field and therefore the more critical must focusing be.

A scale on LEICA lens mounts enables the depth of field to be read at each aperture and each distance setting down to 3.5 feet. Objects at distances between those indicated on the scale will be sufficiently sharply defined.

**Example:** With a standard focal length of 50 mm, when the distance scale is set at 25 feet and the lens aperture at f/3.5, the depth of field extends from 20 feet to 40 feet. With the lens stopped down to f/5.6 it will extend from 16 feet to about 60 feet. At f/11 all objects beyond 12 feet will be in focus.

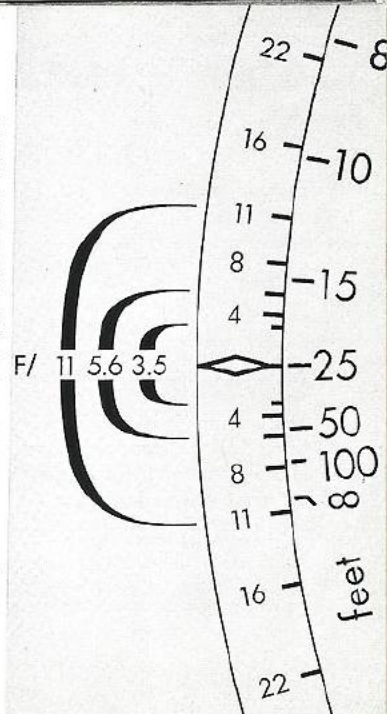

## VIEWFINDER and RANGEFINDER:

### 11 TWIN EYEPIECE

This carries the eyepieces of both viewfinder and rangefinder so that only a slight movement of the head is necessary when changing from one to the other.

Correction lenses can be fitted to the twin eyepiece, enabling users with defective eyesight to operate the LEICA without glasses. Such lenses are made to the user's optician's prescription.

### 12 VIEWFINDER

The built-in viewfinder indicates the view embraced by the standard 50 mm. lenses. When lenses of other focal lengths are in use, the universal viewfinder, which fits into the accessory shoe (17), must be brought into use.

The viewfinder of the LEICA If is detachable since this camera often serves special purposes, i. e. scientific photography, where other methods of observation are advantageous (micro-attachment, reflex housing etc.).

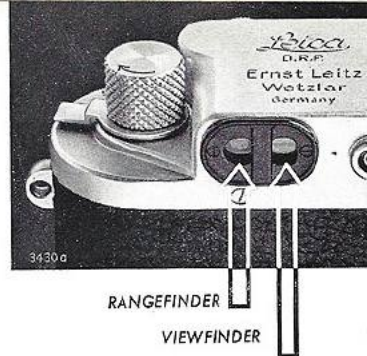

Place the eye close to the twin eyepiece. Care should be taken to look squarely through the centre of each eyepiece.

16

12 THE VIEWFINDER of the LEICA If is of the reflecting type and can be used to good advantage on models II f and III f.



As the field covered by 50 mm. lenses is shown in its natural size this reflecting finder allows the use of both eyes, the brilliant field frame appearing in the observer's unimpaired natural field

of view without the risk of eyestrain. A dotted line along the upper edge enables one to make adequate allowance for parallax in the case of close-ups (distances less than 10 feet).

17

### 13 COUPLED RANGEFINDER



In miniature photography accurate focusing is essential for perfect definition and sharp enlargements.

Former visual examination under the black cloth is now replaced by the movement of a single finger.

The rangefinder coupled with the LEICA lens measures the distance and at the same time focuses the lens accurately on that distance.



Focusing is effected by means of the lens focusing lever (8). When the lens is set at "infinity", near objects appear to be "double" when viewed through the rangefinder. When the lever is operated so that the two images of an object coincide the lens is focused on that object. All interchangeable LEICA lenses up to 13.5 cm. focal length are automatically coupled with the rangefinder when screwed into the camera body.

Only LEICA If differs in that it has an attachable rangefinder without provision for coupling lenses (A conversion into models If f or If f is possible).

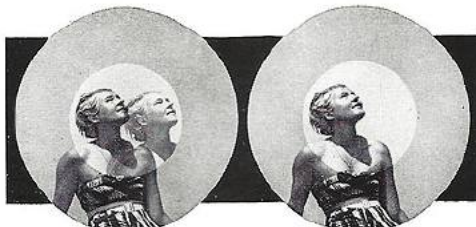

Out of focus

Correct focus

### How the Coupled Rangefinder Works:

As the lens is focused, the backward and forward movement is communicated by a lever to the rangefinder, the precision of which resembles that of a high-grade microscope.

### 14 ADJUSTMENT OF RANGEFINDER TELESCOPE

The accuracy of the LEICA rangefinder is augmented by a built-in telescope having a magnification of 1.5. By means of the small lever (14) it may be focused on distant objects. It will also compensate for slight eyesight defects (between -2 and +1.5 dioptres).

To demonstrate the operation of the rangefinder: Sight, through the rangefinder, an object about 12 to 15 feet away, the lens being set to "infinity". Cover the left hand rangefinder window with the middle finger of the left hand. Look centrally into the rangefinder eyepiece. The object will be seen in a small circular field. Adjust lever (14) until the greatest possible sharpness is obtained. When the finger is removed from the window a double image of the object will be seen in a

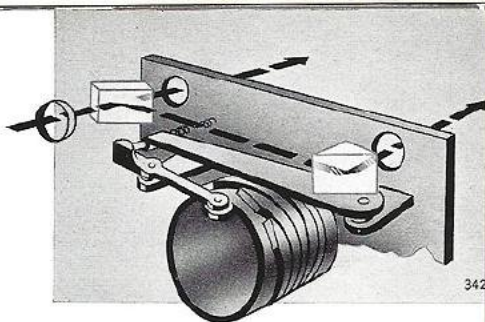

342

larger circular field. Adjust the lens by lever (8) until the two images coincide. The lens is then accurately focused on the selected object. Unless the small field appears exactly in the centre of the larger, the line of sight is sideways and incorrect. Bearing this in mind will quickly enable the LEICA user to focus rapidly and accurately.

When working at short distances it is advisable to focus the lens by scale on the appropriate distance and correct slight difference by approaching or receding from the subject until the rangefinder images merge.

To enhance the colour differentiation of the rangefinder images a small orange filter in mount can be fitted to the left window (13).

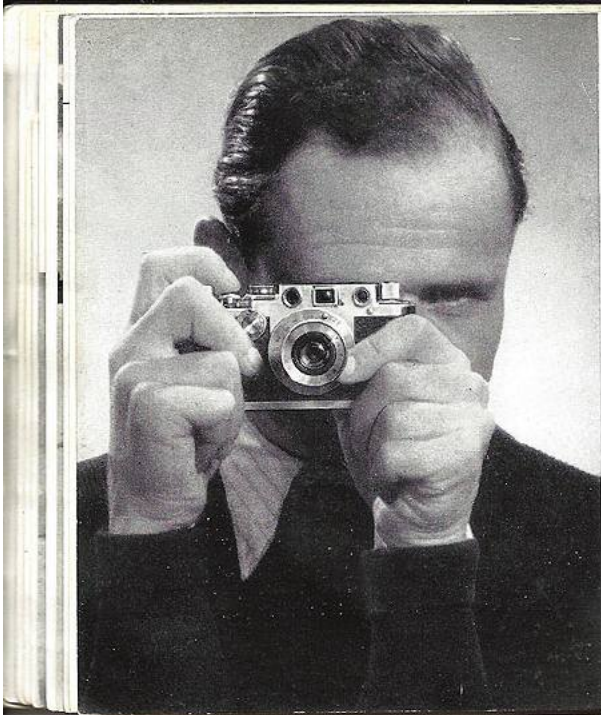

### HOLDING the LEICA:

Grip the LEICA with the right hand so that the rounded end of the base-plate rests in the palm. The index finger should rest lightly on the shutter-release button. It is important that the camera is cupped in the base of the palm counteracting the pressure of the finger on the release. The other end of the camera is gripped in the left hand, with the index finger on the focusing lever. Hold the camera steadily against the head with the twin eyepiece immediately in front of the eye. Press the elbows to the chest and stand with the feet well separated.

Press the release button gently but firmly, taking care not to jerk. Apply pressure with the forefinger only and maintain pressure until the shutter has completed its run.

20

### THE WRONG WAY:

The camera is not held firmly and may give way to the pressure on the release button when not cupped in the base of the palm. The result will almost certainly be a blurred picture. In addition to the method of holding the LEICA described on page 20, experienced users hold their breath at the moment of release.

Some enthusiasts boast that they are able to hold the camera steady for a whole second. However, it is always safer to set the camera on a firm support when using exposure times of the slow speed dial, i. e. shutter speeds between  $\frac{1}{25}$  and 1 second.



21

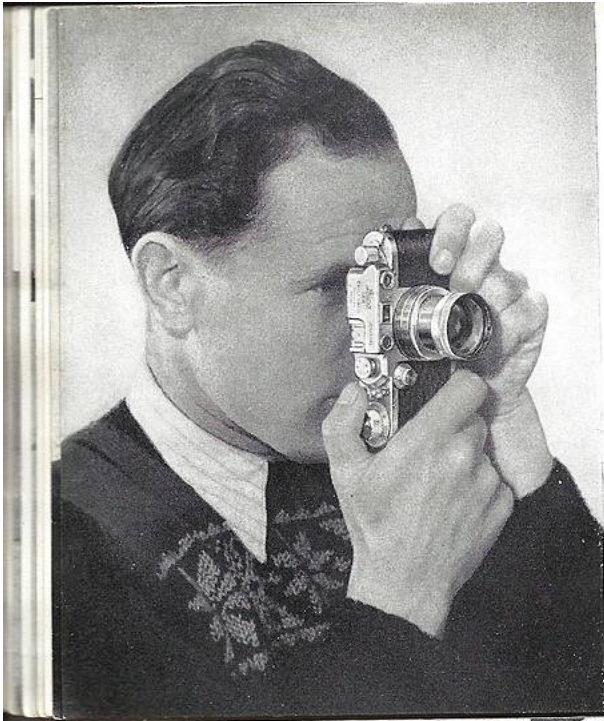

### VERTICAL PICTURES:

Grip the LEICA with the right hand with the thumb on the release button and the fingers exerting counter pressure. The upper end of the camera is grasped with the left hand, one finger of which operates the focusing lever. The top of the camera should rest against the forehead. Thus held, the camera can be operated without jerking.

*Slow-speed, hand-held snapshots are not difficult . . .*



22

### THE SECOND METHOD

of taking vertical pictures, popular when changing from horizontal to vertical position or vice versa.

Grip the LEICA as described on page 20, then turn to the vertical position.

*. . . if ingenuity is called upon.*

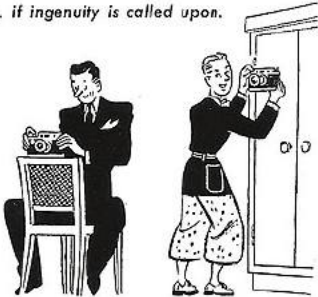

23

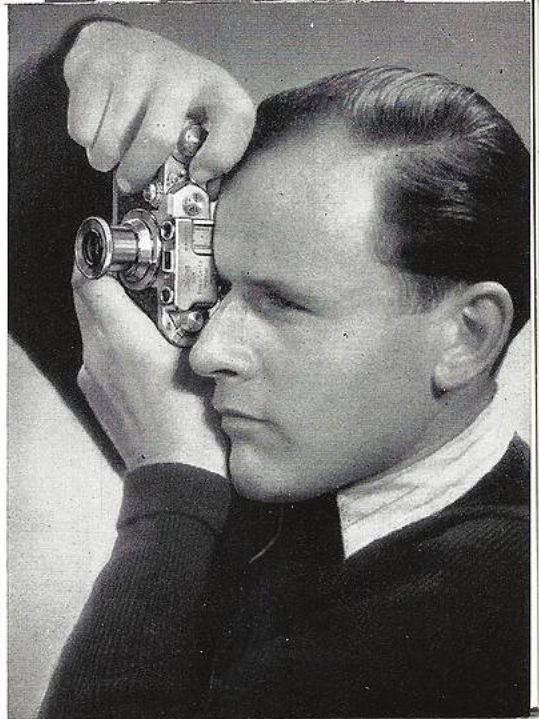

1



Remove LENS CAP.

CAMERA DRILL

2

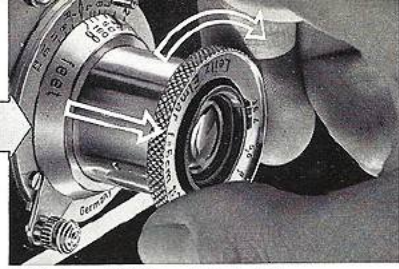

Withdraw LENS and lock it by turning clockwise to the stop.

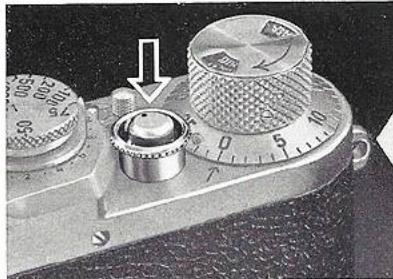

... gently press RELEASE BUTTON.

24

8

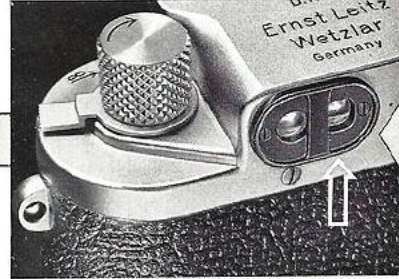

FOCUS lens by means of the rangefinder. Move eye back to viewfinder and ...

3

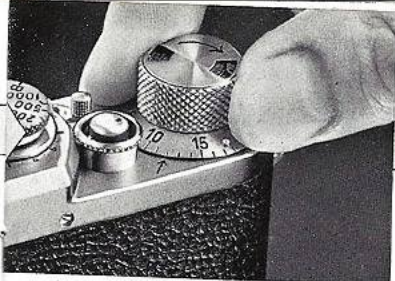

Turn WINDING KNOB to the stop.

4

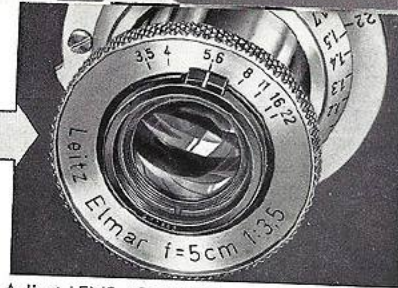

Adjust LENS APERTURE.

6

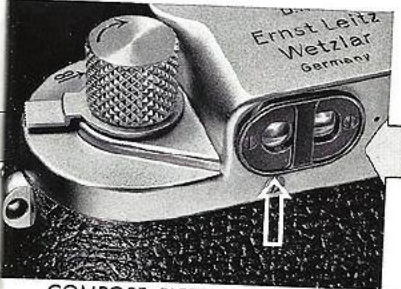

COMPOSE PICTURE in viewfinder and FOCUS LENS through rangefinder.

5

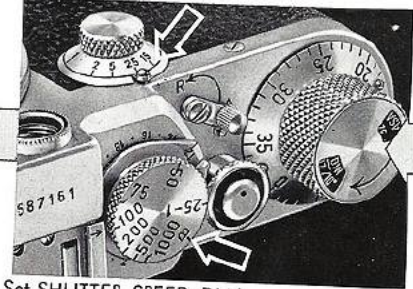

Set SHUTTER SPEED DIAL.

ERNST LEITZ GMBH WETZLAR

25

## FILM CARTRIDGES, SPOOLS, CASSETTES

The principal manufacturers supply 35 mm. perforated film as used in the LEICA in various degrees of sensitivity etc. and issue the following:

1. *Daylight Loading Cartridges* which are simply inserted in the camera in daylight in the same way as LEICA film cassettes. They should not be loaded a second time.
2. *Daylight Loading Spools* which consist of a standard length of film with opaque paper leaders and wound on a centre spool. Directions for use are supplied with the spools.
3. *Darkroom Loading Spools* which contain ready-trimmed lengths of film which require to be loaded into the LEICA cassette in the dark-room.
4. *Bulk Supply.* This is available in lengths of 5, 10, 15 metres and upwards. In the darkroom the required length is cut off, loaded into the LEICA cassette and trimmed (see page 30). The LEICA film cassette holds 1.6 m. (approx. 5 1/4 feet) of film, sufficient for 36 exposures.

### The Ever-Ready Case:

*The LEICA is best kept and carried in the ever-ready case. To remove the LEICA from the case, loosen the bottom screw.*



WRONG



RIGHT



*Caution: When using a new case and when taking vertical pictures care should be taken that the hinged portion does not swing in front of the lens.*

26

## LOADING the LEICA

The fact that exposures as short as  $1/500$  or  $1/1000$  sec. can produce successful pictures is sufficient indication of how minute an amount of light may affect a film. LEICA cassettes and daylight loading cartridges are light-tight but even so, they should never be exposed to direct sunlight. Always load and unload the camera in the shadow of the body in the absence of other light protection.

Before opening the LEICA make sure that the film has been rewound into its cassette. If there is any doubt about the camera being loaded, pull out the rewinding knob (15) and turn it in the direction of the arrow. If resistance is felt the camera is loaded and the film should be wound back into the film cassette.

27

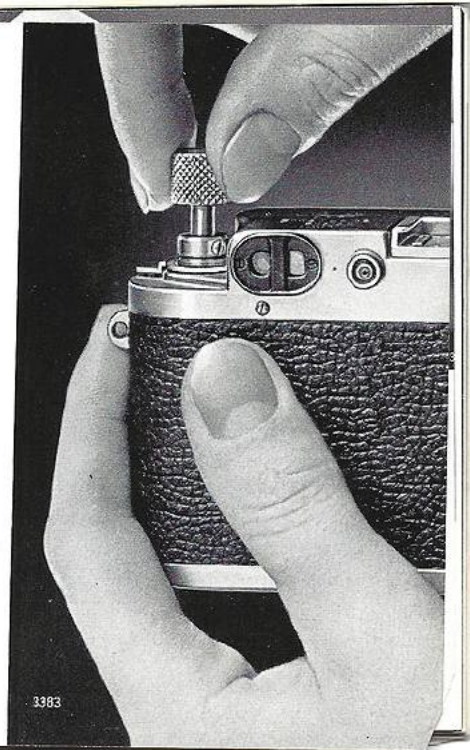

3383

**TO LOAD THE LEICA :**

1. Before inserting a new film cassette, set reversing lever (16) to **A (Advance)**. Wind and release the shutter to make sure that it is in order. Wind the shutter again but do not release it.
2. Open the camera by raising the locking handle on the baseplate and

turning to "OPEN" and lift the baseplate. (Some models are marked "AUF" (open) and "ZU" (close).)

3. Remove the take-up spool from the camera.
4. Place the LEICA on the table as shown in the illustration.

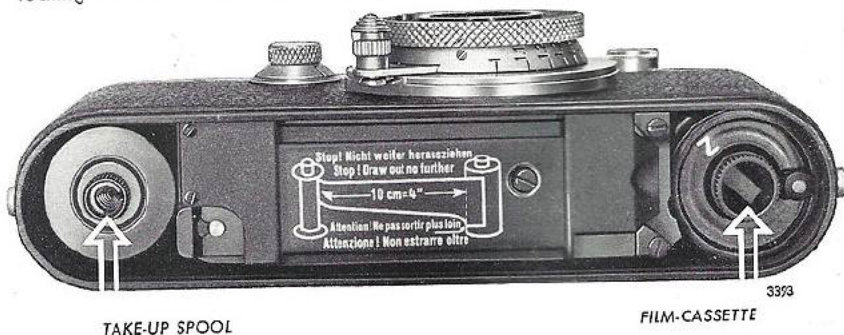

TAKE-UP SPOOL

FILM-CASSETTE

**LOADING THE LEICA**

5. Hold the take-up spool in the left hand and the loaded film cassette in the right. Both knurled heads should point downwards (see illustration). Insert trimmed end of the film under the clamping spring of the take-up spool as far as it will go. The perforated edge of the film should abut the spool flange.

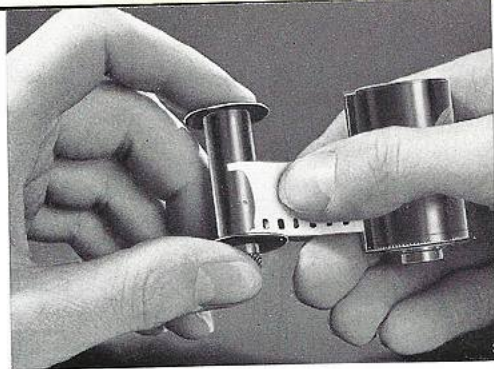

6. Draw the trimmed leader strip from the film cassette slot until two (but no more) perforations on the trimmed edge of the film are visible. (See illustration page 30) The curved mark on the outer shell of the LEICA cassette indicates the correct position of the film.

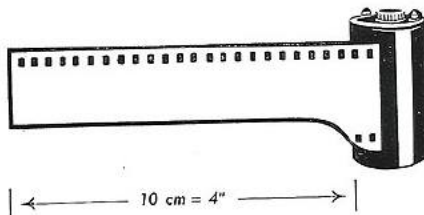

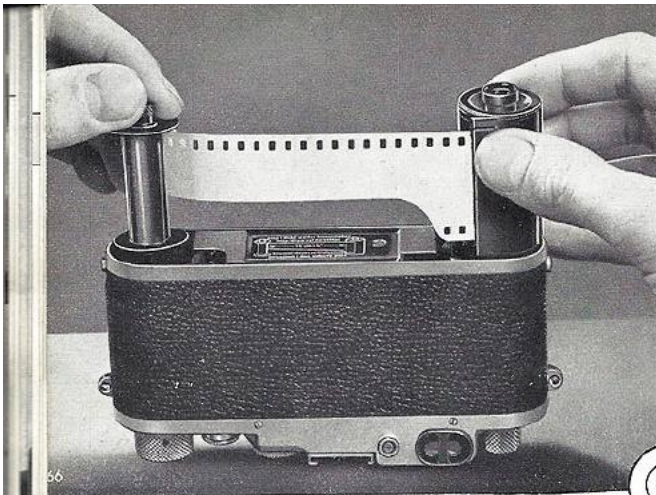

**LOADING THE LEICA**

*The safety spring of the standard LEICA film cassette should always lie in this corner.*

*With properly trimmed film no more than two perforations should be visible on the trimmed edge.*

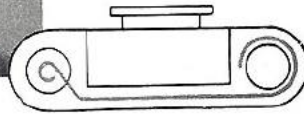

**7.** Introduce the take-up spool and film cassette into camera simultaneously, knurled heads pointing upwards. The trimmed film will then enter the slot along the back of the camera. If the cassette will not drop right down, turn the rewinding knob (15) slightly.

*Check the path of the film by this diagram, the emulsion side must face the lens.*

**LOADING THE LEICA**

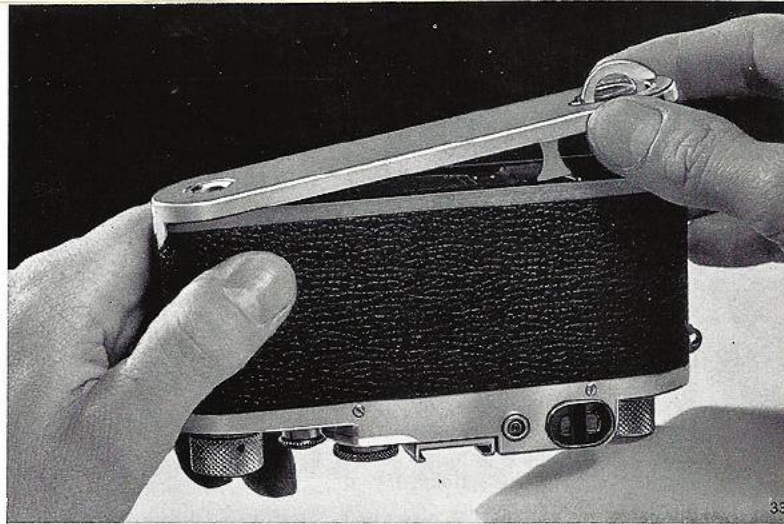

**8.** Hook the baseplate over the pin, close it and turn the locking handle to "CLOSE" (or ZU). The camera is now light-tight.

#### LOADING THE LEICA

**9.** Turn the rewind knob (15) carefully in direction indicated by the arrow until a slight resistance is felt. This will tighten the leader strip. Press the release button (3) and turn winding knob once again.

**10.** Turn exposure counter (2) anticlockwise to 0, release shutter and again turn the winding knob. While the winding knob rotates clockwise, the rewind knob should turn in the opposite direction to the arrow, viz. anticlockwise. This will indicate that the film is travelling properly. The exposure counter will now be pointing to 1 and the LEICA is ready for use.

#### *If the film has not been correctly inserted . .*

it may disengage from the take-up spool and will not advance. This fault will be recognized by the rewind knob failing to rotate while the winding knob is being turned. The film must be re-inserted: first set reversing lever (16) to R, then turn rewind knob (15) in the direction of the arrow, *only so long as the release button continues to rotate*. When the latter ceases to rotate the film will have passed the release shaft and only a very short length will be protruding from the mouth of the cassette. Should the end of the film be drawn into the cassette it will be necessary to go into a darkroom to withdraw the leader.

32

#### UNLOADING the LEICA

When the full length of film has been exposed it will be impossible to turn the winding knob without exerting undue force. It will be necessary to rewind the film into the cassette. Before doing so verify that the slow-speed dial is not set to T or the shutter might be open and the film would be exposed while being rewound. To be doubly sure fit the lens cap while rewinding.

**1.** To unload the camera set the reversing lever (16) to R (Reverse). This disengages the automatic coupling of the film transport and the shutter mechanism.

**2.** Pull up the rewind knob (15) and turn in the direction of the arrow until resistance is felt. This will indicate that the film has been unwound from the take-up spool and is being held merely by its tip under the spring of the spool. Wind to overcome resistance, and after two complete turns the film will be completely rewound into the cassette.

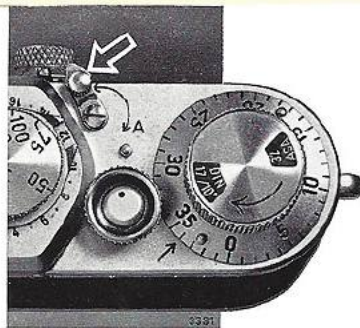

If a partially exposed film is removed from the camera and the unexposed portion is to be used at a later date, the film must not be fully rewound into the cassette. Watch the release button carefully when rewinding and stop as soon as it ceases to turn. (See also page 32.)

**3.** After rewinding the film the baseplate may be removed and the cassette withdrawn. Protect loaded cassettes from dust and light by storing in the original light-metal containers.

33

## FLASH SYNCHRONIZATION

The LEICA has provision for flash synchronization at the various shutter speeds. An adjustable contact scale (18) with red figures is fitted under the fast shutter-speed dial (5).

The contact scale allows of adjusting the built-in shutter synchronization in accordance with the flash peak of all commercial types of flash bulbs and also electronic flashes.

The appropriate setting of the contact scale for any exposure time required is taken from the Tables printed on pages 38–39. Similar folding Tables are supplied for retention in the ever-ready case. The circular plug socket to take the connecting cable of the flash attachment is built-in at the right hand side of the twin eyepiece of the rangefinder and viewfinder.

Special attention is drawn to the fact that these Tables are only valid for cameras with RED contact numbers and distance calculation in FEET. Special tables are available for earlier III f cameras with BLACK contact numbers.

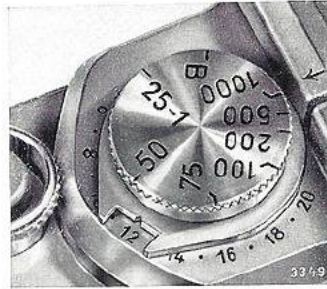

34

The camera plug held in a horizontal position and with the arrow engraved on it pointing towards the twin eyepiece is pushed into the flash socket (19) of the LEICA and secured there by turning it downwards so that the arrow now points to the top. To remove the plug, turn it so that the arrow is horizontal again and pointing to the twin eyepiece.

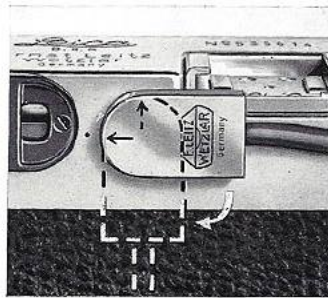

35

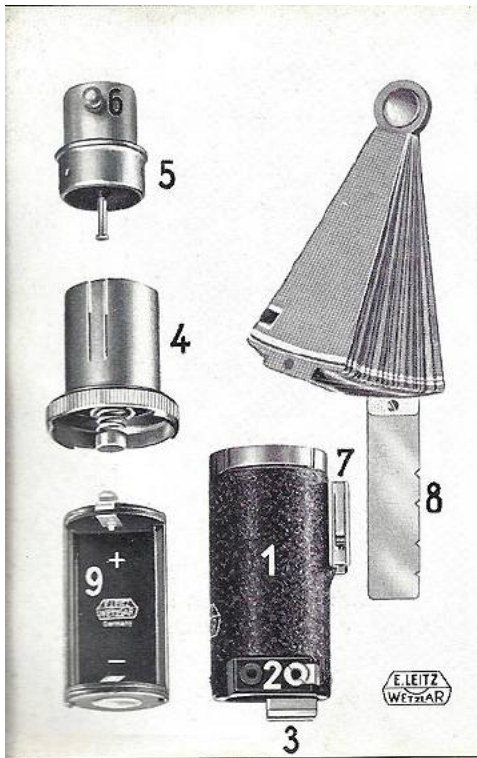

The LEITZ flash attachment is fitted to the accessory shoe of the camera or to the shoe of the adjustable holder for the flash attachment. The unit consists of the battery container (1) with lateral socket (2) for inserting the two-pin plug of the connecting cable, tripod thread (3), detachable holder for large flash bulbs with E. S. cap (4), adapter (5) with ejecting device (6) for small flash bulbs with S. C. C. cap, reflector holder (7) and collapsible (segmented) reflector (8), and connecting cable.

The battery container includes an adapter (9) with tubular capacitor and with holder taking a small commercial 22.5 volt dry battery (commonly used with hearing aids).

Successful firing is guaranteed by the capacitor. The adapter with capacitor can be fitted, without modification, in place of the battery holder supplied with earlier flash attachments. The flash bulb socket (4) is detached by a slight left turn and similarly replaced by a right turn.

The current supplied by the battery, even after long use, will still be sufficient for firing. Ignition is, therefore, practically independent of the condition

36

of the battery as long as it is not completely exhausted. The capacitor is charged by inserting the flash bulb or the test filament bulb (6 volts, 0.05 amps). No bulb should, therefore, be kept inserted if the flash attachment is not in use.

The holder for flash bulbs with E. S. cap (4) takes the adapter (5) for the small flash bulbs with S. C. C. cap. This adapter is turned until its pins engage the springs of the holder and the red dots on either part are in alignment. By pressing the knob (6) of the ejecting device the hot bulb can be ejected immediately after firing.

The collapsible reflector is so attached to the holder with click stops (7) that the flash bulb is in the centre of the reflector. Radius and surface of the reflector are designed to produce a pleasing soft lighting covering a wide angle, so that the 35 mm. wide angle lens can also be used for flash photographs. With the reflector folded the flash attachment requires a minimum of space.

One or more flash attachments can be connected to the synchronized LEICA and fired simultaneously at various distances (mounted on tripods) to give special lighting effects. In this case a long connecting cable and multiple socket have to be used with the normal flash attachment cable.

37



Exposure Guide  
for LEICA-Cameras with RED Flash Synchronization Scale

Table ①

Shutter Speed →		1/25	1/50	1/75	1/100	1/200	1/500	1/1000	
Contact Number →		16	13	7	5	2	1	0	
Flash Bulbs (Type FP) for Focal Plane Shutter	Philips PF 24, Osram SO Gen. El. USA PH 6 Sylvania USA FP 26 West Japan FP 6 A	90	70	60	50	40	25	20	Guide Numbers
	Philips PF 45	115	100	80	70	40	30	—	
	Gen. El. USA PH 31 West Japan FP 31 Sylvania USA No. 2 A	145	115	90	80	50	35	25	
	Osram S 2 Gen. El. Brit. No. 22	200	140	120	100	70	50	35	

1. Adjust red scale of synchro-dial below the shutter speed dial in accordance with the CONTACT NUMBER given in the table for the required shutter speed.
2. Look up the GUIDE NUMBER for the flash bulb and shutter speed used, divide by the distance (in feet) between bulb and subject and set lens diaphragm to the figure thus ascertained. This adjustment ensures satisfactory exposures

on films of medium speed 17/10° DIN (28° European Scheiner, 27° B. S. & A. S. A. Logarithmic Index).

3. Correct the lens diaphragm setting when using high-speed or slow films by changing to a higher or lower stop number. A change of one stop is required for a speed difference of 3/10° DIN, (3° Scheiner or 3 B. S. & A. S. A. Log. Index units).

Consult special table for LEICA III f with BLACK contact scale.

Directions for Electronic Flashes  
and Flash Bulbs for Central Shutters

Flash bulbs specially made for focal plane shutters (Table 1) ensure best results with the LEICA but those made for central shutters of the between-lens type for ordinary cameras can also be used. The latter flash bulbs emit a shorter flash so that slightly uneven illumination of the negative may be caused, especially with short exposures. The values given in Table 2 are based on data and graphs supplied by the makers of the bulbs. To make the best use of the light available, somewhat increased negative development times are advisable. This is specially important with photographs taken with the aid of electronic flash equipment.

If on one film strip daylight and flash photographs are being made and therefore an increased developing time is not feasible, it is recommended to use for flash photographs the next larger diaphragm opening of the lens than that derived from the Table and calculation. Example: guide number 55 and distance 10 feet require f/5.6, so that under the above circumstances f/4 should be preferred.

Table ②  
Flash Settings for the synchronized LEICA with  
red Synchro-dial.

Shutter Speed →		1/25	1/50	1/75	1/100
Flash Bulbs	Press 40	13 135	12 105	6 85	4 80
	Osram S 1	10 115	11 80	6 65	4 60
	Philips PF 56	11 135	12 105	6 85	4 80
	Philips PF 25	9 95	10 75	5 55	
	Philips PF 14	9 60	10 55	5 35	
	Philips PF 3	9 50	10 35	5 25	
	Osram XO	3 65	6 55		
	Osram XP	1 50	5 45		
Electronic Flash (without delay)			20		
Electronic Flash (with delay)		0			

To use this table consult Directions 1. to 3. on preceding page.

### Simplified Testing Method for Built-in Flash Synchronization.

The cause of failures is usually found outside the camera. The voltage of batteries may have dropped by long storage so much that there is no ignition of flash bulbs. The synchronization is checked as follows: the two-pin plug of the connecting cable is inserted into the flash attachment fitted with a test filament bulb or connected to a torch battery with a filament bulb in series connection. The filament will light up when the pins of the plug, while inserted in the socket, are shorted. To test the cable the camera plug on the other end of the cable must also be carefully shorted.

For actually checking the LEICA synchronization, push camera plug into the socket of the LEICA and test series contact with shorted main contact as follows: Wind shutter, set speed dial to  $\frac{1}{25}$  sec. and synchro-dial to 2, 3, 4 or 5. Press down release button (shutter will release). The test filament bulb will light up only for a fraction of a second due to the capacitor. If a commercial mono-cell battery with suitable bulb (1.5 volt) is used with the flash attachment for checking purposes, the bulb will light up on depressing the release button and go out again as soon as the pressure is released.

For checking the various contact settings of the synchronization, set shutter speed and synchro-dial as follows:

Shutter speed	1000	500	200	100	75	50	25
Synchro-dial	0	1	2	5	7	13	19

The shutter speed dial is held firmly and the release button pressed down. No contact, the bulb does not light up. Then the shutter speed dial is allowed to revolve slightly. Contact is established, the bulb lights up. On rewinding the shutter speed dial to the stop the current must be switched off again. With these tests proper flash synchronization is established. In case of difficulty with electronic flashes it is advisable to have the insulating resistance checked by an expert (electrical engineer) at the two-pin plug of the cable while the camera plug is pushed in position. The test voltage should be not more than 220 volts, the insulating resistance at least 2 megohms. If the camera does not conform with this requirement it should be sent to our works or our official agency.

## CHOICE OF FILM MATERIAL:

A wide variety of films of differing speeds and other characteristics is available, enabling the LEICA photographer to select the type most suitable for any particular purpose.

**Medium Speed Films** with a rating of about  $16/10$  DIN to  $18/10$  DIN are most suitable for general use. They yield high contrast, fine grain images, exhibit wide exposure latitude and possess high resolving power.

**High Speed Films** should only be used under certain circumstances, such as poor light, indoor and theatre work and sports photography when high shutter speeds are essential. High speed can only be realized at the expense of some coarsening of grain structure and therefore of resolving power.

**Slow Films** possess particularly fine grain and yield the highest contrast. They are most suitable when the reproduction of fine detail is required and length of exposure is unimportant. The copying of documents and drawings is best done on slow films.

Film manufacturers express the speeds of their materials by various systems. The more frequently used ratings employed by film and exposure meter manufacturers are shown in the accompanying table.

DIN	B. S. & A. S. A.		General Electric	Weston	American Scheiner	European Scheiner
	Arithmetic	logarithmic				
$10/10$	6	19°	8	5	16°	20°
$11/10$	8	20°	10	6	17°	21°
$12/10$	10	21°	12	8	18°	22°
$13/10$	12	22°	16	10	19°	23°
$14/10$	16	23°	20	12	20°	24°
$15/10$	20	24°	24	16	21°	25°
$16/10$	24	25°	32	20	22°	26°
$17/10$	32	26°	40	24	23°	27°
$18/10$	40	27°	48	32	24°	28°
$19/10$	48	28°	64	40	25°	29°
$20/10$	64	29°	80	50	26°	30°
$21/10$	80	30°	100	64	27°	31°
$22/10$	100	31°	125	80	28°	32°
$23/10$	122	32°	160	100	29°	33°
$24/10$	160	33°	200	125	30°	34°
$25/10$	200	34°	250	160	31°	35°

Scheiner, DIN, ASA/BS (log) ratings progress by three units per doubling of speed. In the other systems, doubling of the speed figure denotes a doubling of the film speed.

## CORRECT EXPOSURE:

A good exposure meter greatly simplifies exposure problems, but even without a meter, it is possible to acquire a facility for estimating exposures based on previous experience. From the start, make two different exposures of each subject and compare the result after development. The accompanying table applies to average subjects.

When estimating exposures bear in mind that in a photograph bright objects appear relatively brighter, while dark objects appear darker than they do to the eye. This is because the eye adapts itself to the prevailing light. When making a visual estimate of an exposure, therefore, until extensive experience has been gained in bright light, take a second picture giving one third of the estimated exposure. In dull light make a duplicate exposure giving 3 to 5 times the estimated time.

The above applies to black-and-white film. Colour film has little exposure latitude and the use of an exposure meter is recommended.

Snapshots, Groups, Street Scenes, Houses:	f/5.6	1/50 - 1/100
Rapidly Moving Objects, Sports Pictures:	f/4	1/200 - 1/500
Landscapes with foreground:	f/8	1/25 - 1/75
Open Landscapes:	f/8	1/50 - 1/100
Open Sea, Snow Scenes:	f/8-f/11	1/50 - 1/200
Outdoor Portraits in the shade:	f/3.5	1/25 - 1/50
Indoor Portraits near window:	f/2	1/5 - 1/50
	F/3.5	1/2 - 1/25

The above exposures are for medium speed films  $17/10$  DIN (28° European Scheiner, 27° B. S. & A. S. A. Logarithmic Index) and a clear sky during the summer months between 10 a. m. and 4 p. m. In spring and autumn double these exposures and in the winter months multiply by four. High-speed films will require only half the exposures indicated.

The geographical latitude also influences exposures. Those shown apply to the temperate zones.

## THE INTERCHANGEABLE LEICA LENSES

are offered in a large variety of types ranging from wide-angle to telephoto, ensuring excellent results in all branches of amateur photography and most specialized professional work.

Average requirements are often wholly satisfied by one of the 50 mm standard lenses while extra lenses open up many special photographic possibilities.

### General Purpose Lenses:

ELMAR 50 mm. f/3.5 (1), SUMMITAR 50 mm. f/2 (2)

### Ultra Speed Lenses:

SUMMARIT 50 mm. f/1.5 (3)

SUMMAREX 85 mm. f/1.5 (4)

### Wide-Angle Lens:

SUMMARON 35 mm. f/3.5 (5)

### Long-Focus Lenses:

ELMAR 90 mm. f/4 (6), HEKTOR 135 mm. f/4.5 (7)

### Telephoto Lens:

TELYT 200 mm. f/4.5 (8)

The TELYT 200 mm. can only be used in conjunction with the mirror reflex housing (9), which also takes the HEKTOR 135 mm. when fitted with a short mount.

44

## THE LEICA LENSES

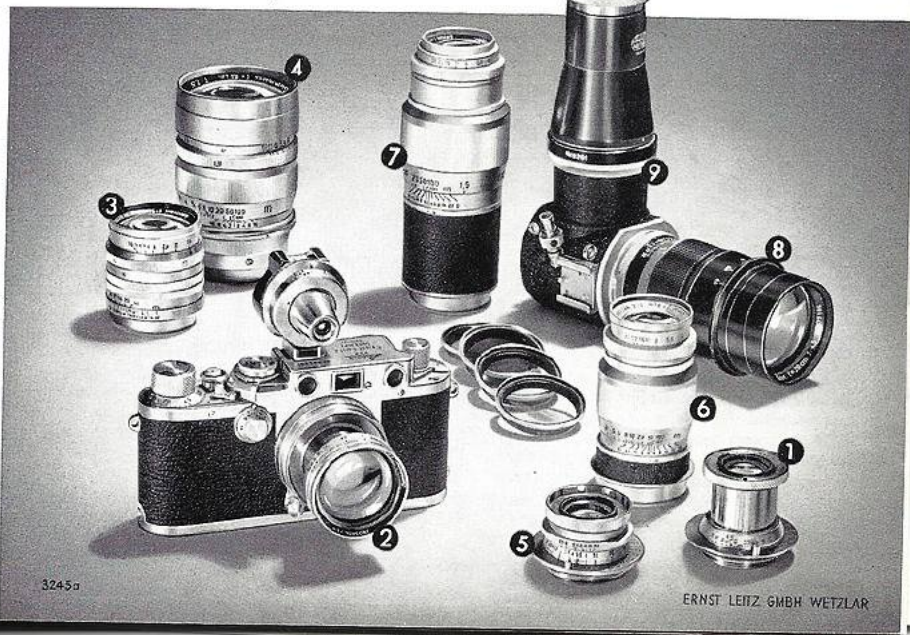



#### THE UNIVERSAL VIEWFINDER

is designed for lenses of 35 mm. up to 135 mm. focal length and presents the fields covered in natural left to right and vertical orientation, the field diaphragm being operated by a milled ring with click stops. A graduated lever provides the necessary parallax correction for close-ups.

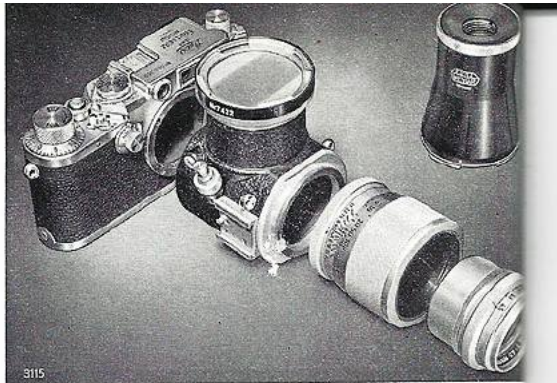

#### THE MIRROR REFLEX HOUSING

is intended for viewing and focusing directly on a ground glass screen with the aid of a 5x magnifier. This device is primarily designed for focusing the 200 mm. telephoto lenses but use can also be made of the 135 mm. lens for which a special short focusing mount is available. (For sports photography with the 200 mm. lens a direct vision finder is also offered.)

46



Photo: W. Wissenbach



#### THE UNIVERSAL FOCUSING BELLOWS

in conjunction with the VISOFLEX housing and the 135 mm. lens (used without its normal focusing mount) affords continuous focusing from infinity down to scale 1:1 (natural size). Other scales of reproduction, i. e. magnifications up to 6:1 on the negative, are obtainable with lenses of shorter focal length. An extending lens shade is most effective, particularly when using artificial sources of light or photographing against the sun.

47



#### LENS HOODS

should form part of every camera outfit. They not only screen off direct sun and other extraneous light but prove very advantageous when photographs have to be taken under adverse weather conditions as they will protect the front lens from rain or snow.

#### FILTERS

are recommended in order to increase contrast and improve general picture quality. For all LEICA lenses yellow, green, orange, red, UV protective, and polarizing filters are supplied.

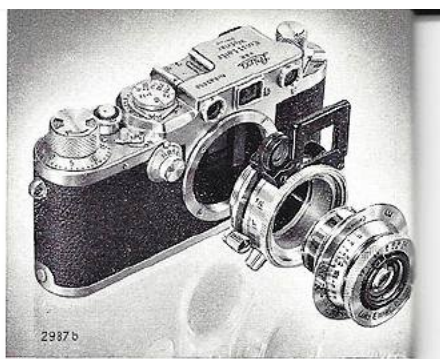

#### THE OPTICAL NEAR FOCUSING DEVICE

enables the LEICA user to focus the 50 mm. ELMAR or SUMMITAR lens for distances between 17 inches and 3 1/2 feet, parallax being automatically compensated. Even in this range use is made of the coupled rangefinder of the LEICA II f and III f.

#### THE BALL-AND-SOCKET TRIPOD HEAD

allows the camera to be adjusted easily and rapidly when taking photographs with the aid of a tripod. The heavy design ensures reliable clamping with any LEICA outfit.

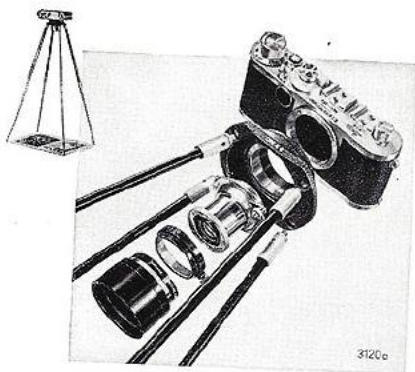

#### AUXILIARY SETTING DEVICES

are made in various models for the LEICA to provide inexpensive mechanical means for copying or similar close-up work. Focusing for scales of reproduction of 1:4, 1:6 and 1:9 (approx. fields 4" x 5 1/4", 5 1/4" x 8 1/4" and 8 1/4" x 11 3/4") is achieved mechanically by 4 extending rods and 3 intermediate adaptors fitting between camera body and 50 mm lens ELMAR or SUMMITAR (B00WU).

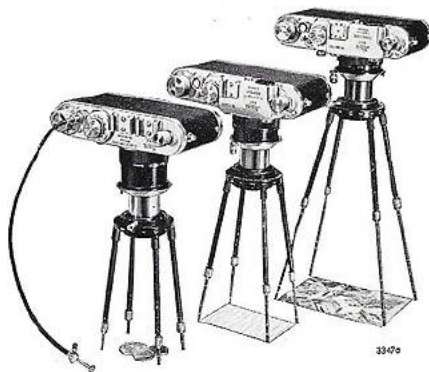

Another outfit which makes use of 3 intermediate collars, 4 extensible rods and a universal clamping collar gives negatives at the scales 1:1.5, 1:2 and 1:3. (Only suitable for ELMAR 50mm, codeword BEH00)

The auxiliary setting device for scale 1:1, i.e. reproduction in natural size on the film, is made with clamping collars fitting either the 50 mm. ELMAR or SUMMITAR (codewords BELUN and BELUN-HESUM).



### Developing Tanks

are available for daylight work, (for example the LEITZ-RONDINAX Tank) and also in simple, less expensive forms for use in the darkroom. The latter tanks are made for 500 and 300 cc. (16 ozs & 10 ozs).

### Small Negatives . . . .

#### LARGE PICTURES

It is not only economical for the LEICA photographer to develop and enlarge his own negatives, but it enables him to utilize to the fullest extent the pictorial possibilities of his subjects and to express individuality in his pictures.

### Enlargers

THE FOCOMAT ENLARGER is fitted with an automatic focusing device to ensure maximum sharpness of every enlargement without tedious adjustment. It renders enlarging as simple as contact printing.

50 mm lenses ELMAR or SUMMITAR may be used in the FOCOMAT and also in the VALOY enlarger which is a simplified form, focusing being non-automatic.

50.

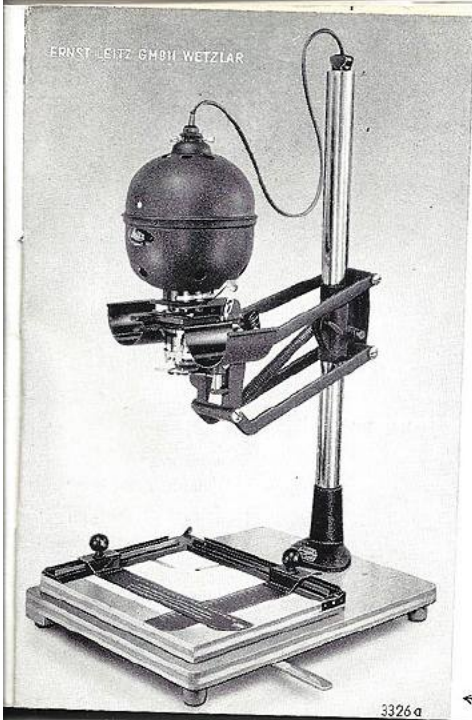

ERNST LEITZ GMBH WETZLAR

3326a

← Focomat I c

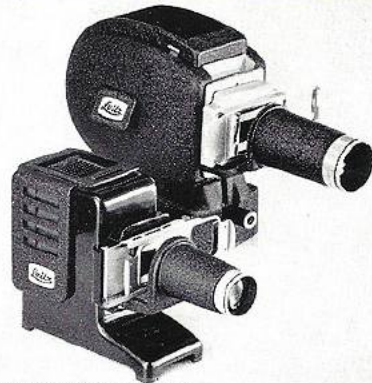

ERNST LEITZ GMBH WETZLAR

3440

### MINIATURE PROJECTION

The brilliance of LEICA photographs projected on to a screen makes for lifelike presentation and most impressive demonstration of the LEICA photographer's work for entertainment, teaching or many other purposes. The LEITZ PRADO projectors 150 & 250 are the ideal equipments for showing black-and-white and colour films in the home or lecture rooms. A high-power model for a 500 or a 750 watt lamp is also available. The PRADO 250 and 500 projectors can be fully adapted for showing 2 1/4" x 2 1/4" slides if desired.

51

## NEVER TRY . . . .

to repair a LEICA if by any chance it has become damaged. Always take it to an authorized LEICA repair service. The LEICA is built by specialists and only specialists should be entrusted with its repair.



## EVERY LEICA and EVERY LEICA LENS

bears a REGISTRATION NUMBER

In case of loss or theft it is important that this number be known. Make a note of all serial numbers and carefully preserve it for reference in case of loss. It may help to recover a lost or stolen camera or lens. If you furnish us with the necessary details, all our technical services will be notified and will retain every camera reported.



52

## FOR MORE THAN TWENTY-FIVE YEARS

Special attention is drawn to the fact that with the genuine LEICA only accessories made by LEITZ are guaranteed for perfect results since only our organization has at its disposal all the highly specialized tools and testing equipment required. We cannot be held responsible for unsatisfactory results obtained with or defects caused by accessories of other make.

the LEICA has been the leading miniature camera. Together with its range of accessories it represents a self-contained photographic system applicable to all fields of amateur or professional photography. Scientists and technicians with special photographic problems are invited to write for our special advice on suitable equipment. Attention is also drawn to the excellently illustrated magazine

### LEICA-FOTOGRAFIE (special edition in English)

with information on all advances in miniature photography. Obtainable through photo dealers.

The *Leica* is manufactured only at the Leitz Works at Wetzlar (Germany) and Midland, Ontario (Canada)

53

## OTHER LEITZ PRECISION INSTRUMENTS

are made for a wide range of applications in many fields of science and industrial activities; they include:

Monocular and Binocular Microscopes for general biological and medical work,  
Binocular Prism Magnifiers and Stereo Microscopes,  
Research Microscopes with Built-in Light-Source,  
Polarizing Microscopes for Transmitted and Incident Light,  
Photomicrographic Apparatus for Plates and Leica Film,  
Attachable Microscope Heating Stages,  
Integrating Stage for Planimetric Analysis,  
Dark Field and Phase Contrast Equipments,  
Polarizing Compensating Photometer,  
Large Half-Shadow Polarimeter,  
Micro-Refractometer, Microtomes,  
Heating Microscope with Automatic Recording (1600° C),

54

Dilatometer for Thermal Analyses (1100° C),  
Toolmakers' Microscopes and Contour Projectors,  
Hardness Tester and Brinell Microscopes,  
Precision Jig Borer and Universal Measuring Machine,  
School Epidiascopes, Slide and Film Strip Projectors,  
Lecture Hall Projection Apparatus and Micro-Projectors,  
Opera Glasses and Prism Binoculars.

ILLUSTRATED CATALOGUES on these and many other instruments are gladly sent upon receipt of details on the type of apparatus required or on the examinations which are to be carried out by optical means.

ERNST LEITZ GMBH WETZLAR  
GERMANY

Branch Works: Ernst Leitz (Canada) Ltd., Midland/Ontario

55



List Photo No. 8385 / I - 53 - AY · Printed in Germany · A. Leipscher KG., Wetzlar

Supplement to page 8 of the Instruction Book for using  
LEICA Cameras If, II f and III f List No. Photo 8385 b

### The built-in self-timer of the III f LEICA

Fig. 1 shows the lever in its normal position (pointing to the top),

Turning this lever downward as indicated by the arrow in fig. 2 the self-timer is wound up and arrests in its final position.

To release the self-timer the small knob at the side is pushed down when after approximately 10 seconds the shutter will be released automatically as seen in fig. 3.

The photographer will have time during the 10 seconds to get in position within the angle of the objective and by doing so to be photographed himself.

The self-timer furthermore is used with advantage when a camera shake is to be prevented which otherwise can be a problem taking photos with longer exposure times and not using a tripod.

ERNST LEITZ GMBH WETZLAR  
GERMANY

VI/55/CLW/L.

